

FOR LEASE - 45,660 SQUARE FEET

151 Domorah Drive, Montgomeryville, PA

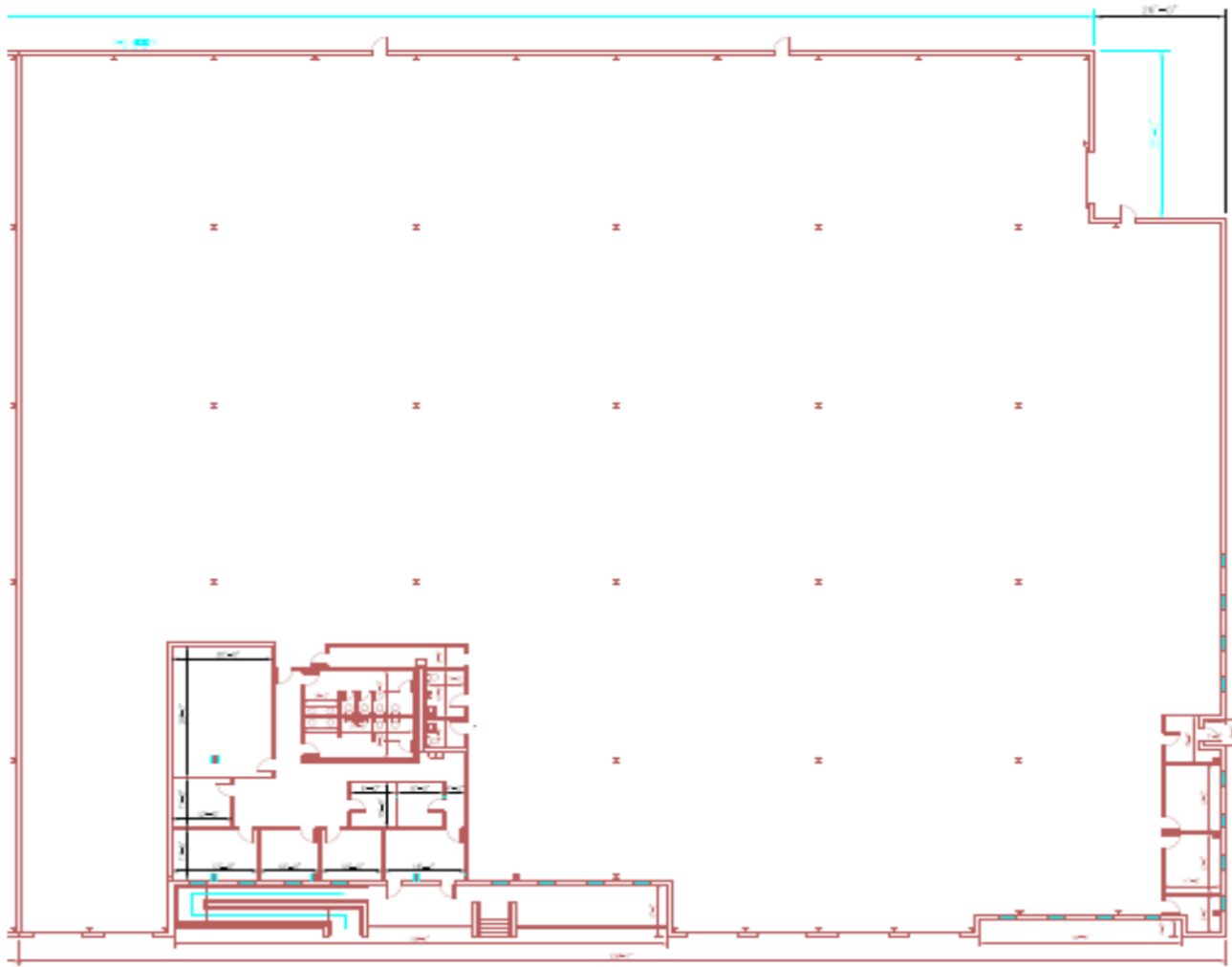



COMMERCIAL REAL ESTATE
 CONSULTANTS

SQUARE FEET
45,660 S.F.

CEILING HEIGHT
24' CLEAR

SPRINKLER
100% WET SYSTEM

BATHROOMS
2 MEN'S & 2 WOMEN'S

ZONING
LIGHT INDUSTRIAL

POWER
800 AMPS; 277/480 VOLTS;
3 PHASE

COLUMN SPACING
40' X 40'

LIGHTING
METAL HALIDE & FLUORESCENT
IN WAREHOUSE

SPACE DIMENSIONS
200' X 454' (998 S.F. CUT OUT
FOR DRIVE-IN DOOR)

OFFICE SPACE
3,600 S.F.

LOADING
6 TAILGATES;
1 DRIVE-IN

PARKING
82 SPACES

OFFICE FLOOR PLAN

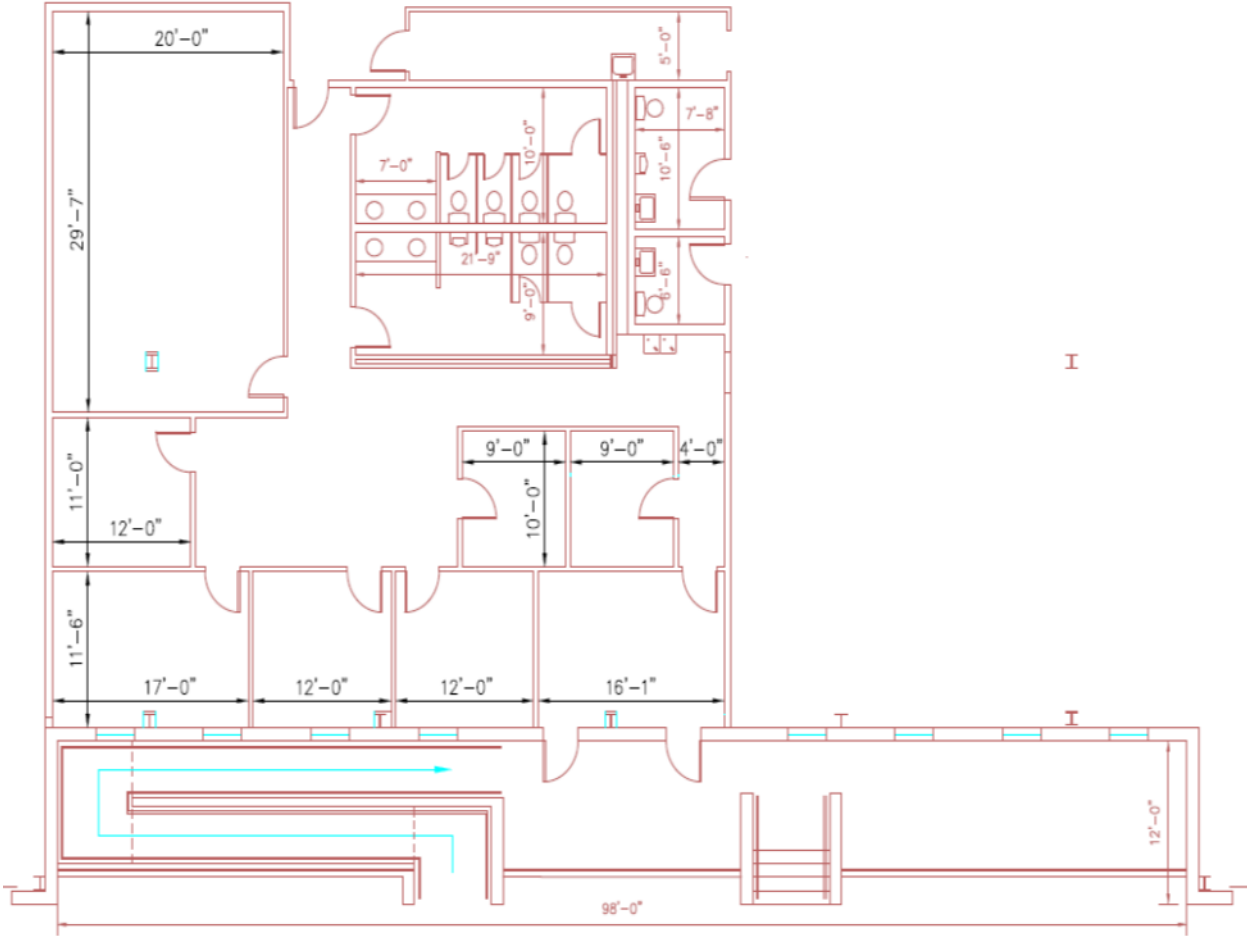

I

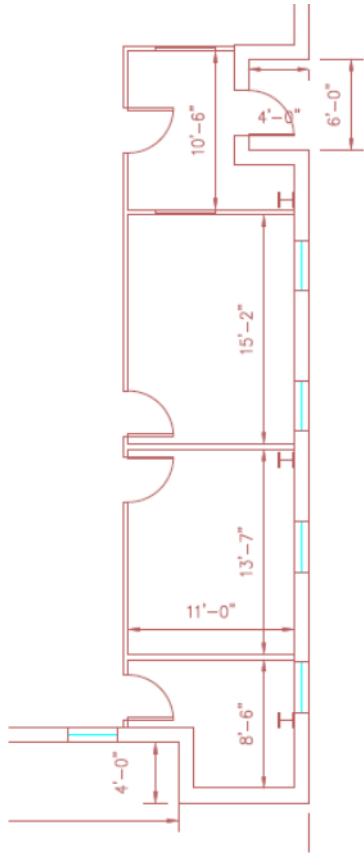

AREA MAP

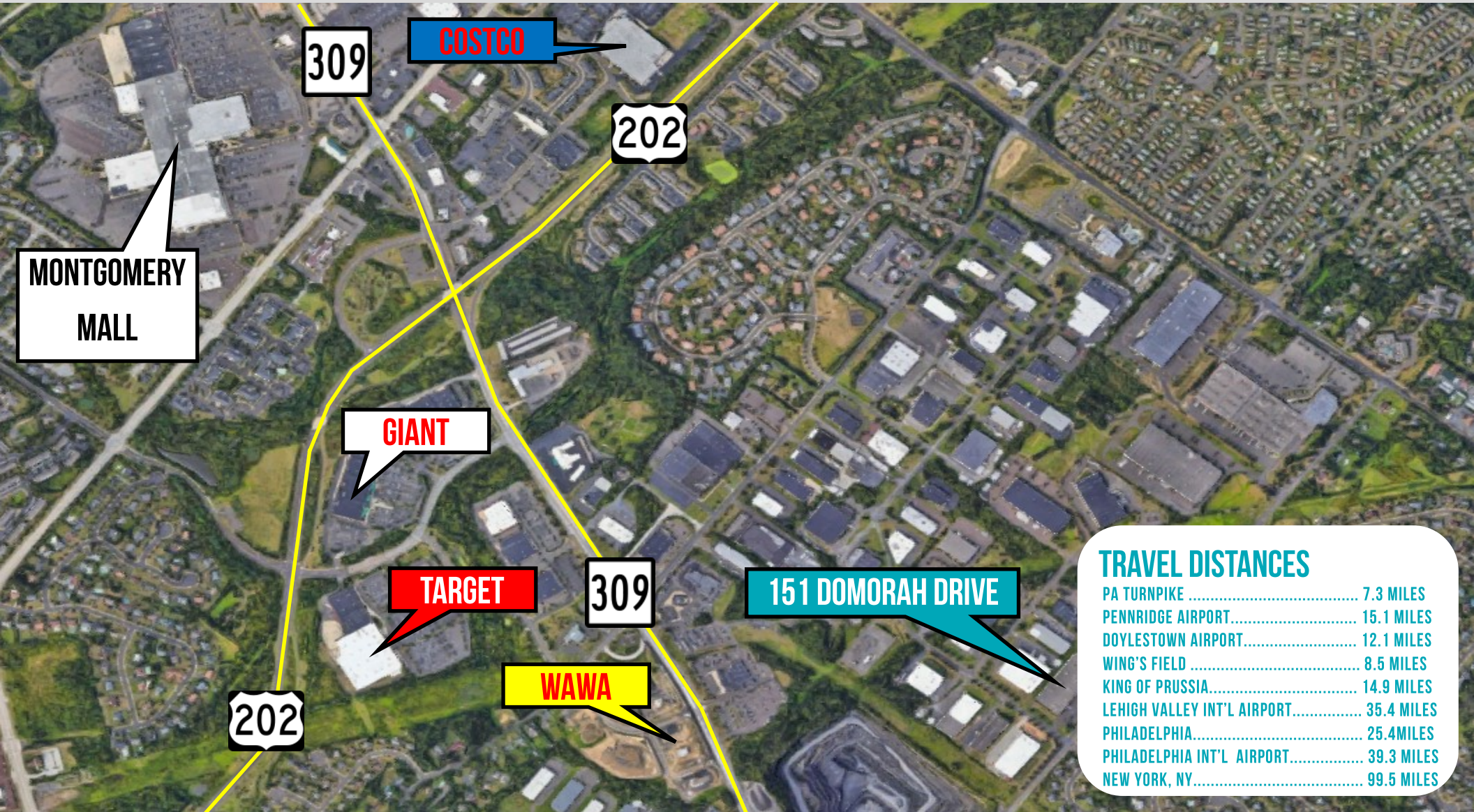

TRAVEL DISTANCES	
PA TURNPIKE	7.3 MILES
PENNRIDGE AIRPORT.....	15.1 MILES
DOYLESTOWN AIRPORT.....	12.1 MILES
WING'S FIELD	8.5 MILES
KING OF PRUSSIA.....	14.9 MILES
LEHIGH VALLEY INT'L AIRPORT.....	35.4 MILES
PHILADELPHIA.....	25.4 MILES
PHILADELPHIA INT'L AIRPORT.....	39.3 MILES
NEW YORK, NY.....	99.5 MILES

AERIAL MAP

